

FOR SALE OR LEASE | LOUISVILLE
17,395 SF
Manufacturing/Distribution Building



5800 Poplar Level Road
Louisville, Kentucky



FEATURES

- 11,658 SF Warehouse
- 5,737 SF of Offices
- 1600 Amp, 480 Volt, 3 Phase Electric
- Insulated Walls and Ceiling
- 5/8" Water Line
- 1" Low Pressure Gas Line
- 8" Sewer Main
- 30 Parking Spaces
- Four (4) Miles From I-65, I-264 and I-265
- Two (2) Docks
- One (1) 12' x 14' Drive-In Door
- One (1) 14' x 14' Drive-In Door
- One (1) 8' x 7' Drive-In Door
- 16' - 17' Clear Height
- PEC Zoning
- 4.29 Acres

For Lease: 6,064 SF; 2,262 SF Office; 3,802 SF Warehouse; 1 Dock; 1 - 12' x 14' Drive-In Door

AGENT

Stephen C. Lannert, SIOR, CCIM, GRI
(502) 394-2508 (direct)
slannert@colliershkm.com

7316 New LaGrange Road • Louisville, KY 40222-4812
(502) 426-1300 (main) • (502) 426-8543 Fax • www.colliersharrykmoore.com

Note: This information was obtained from sources deemed reliable, but its accuracy is not guaranteed.



Individual Memberships
SOCIETY OF
INDUSTRIAL AND
OFFICE REALTORS



FOR SALE OR LEASE | LOUISVILLE
17,395 SF

Manufacturing/Distribution Building

5800 Poplar Level Road
Louisville, Kentucky

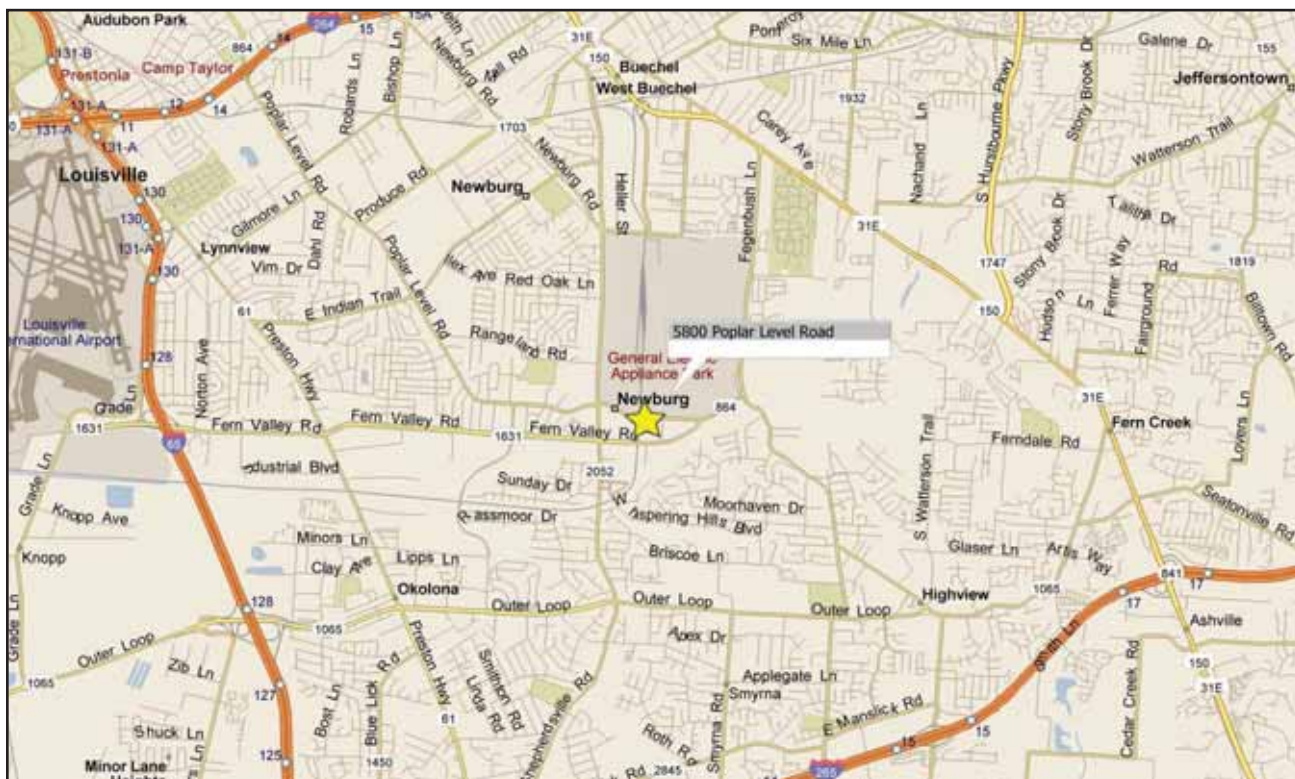
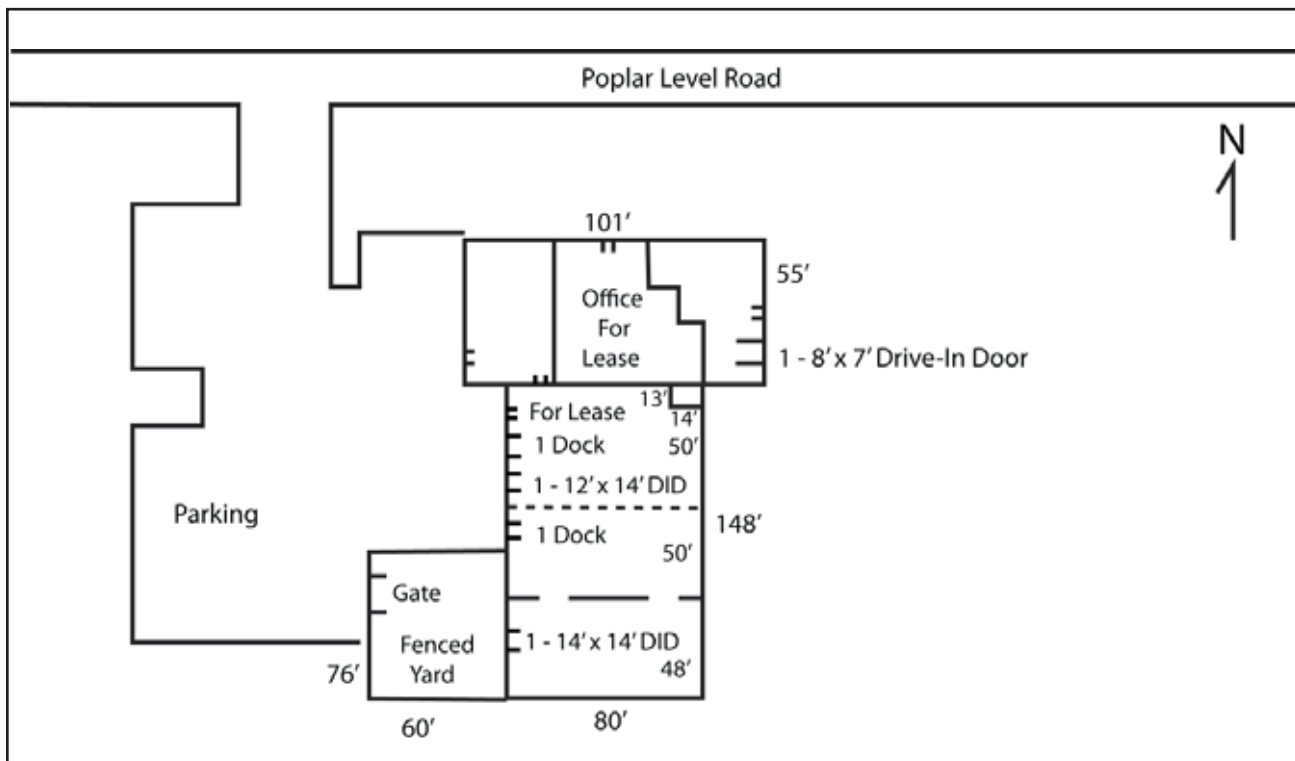

Stephen C. Lannert, SIOR, CCIM, GRI

(502) 394-2508 (direct)

slannert@colliershkm.com



Individual Memberships
SOCIETY OF
INDUSTRIAL AND
OFFICE REALTORS



7316 New LaGrange Road • Louisville, KY 40222-4812

(502) 426-1300 (main) • (502) 426-8543 Fax • www.colliersharrykmoore.com